

Clamshell Desk CS36

Quick start guide

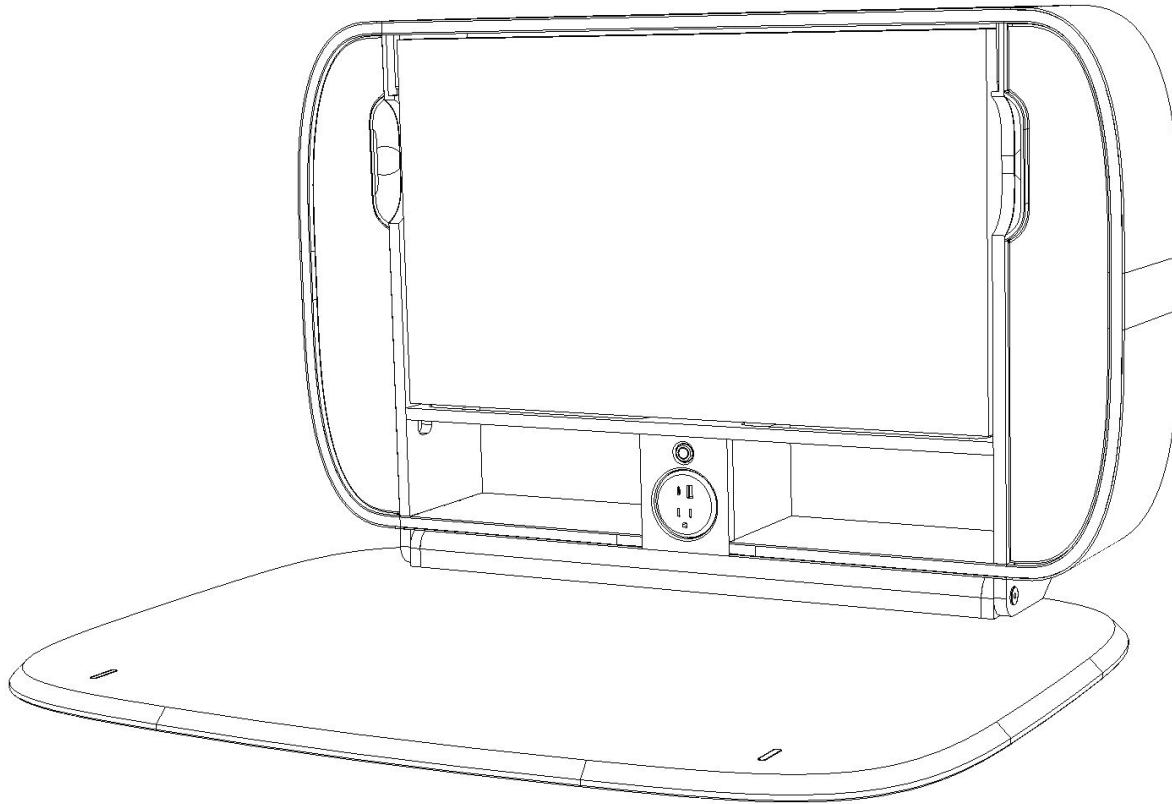

Questions or Comments?

Contact email: hello@friday.furniture

Clamshell Desk at a glance

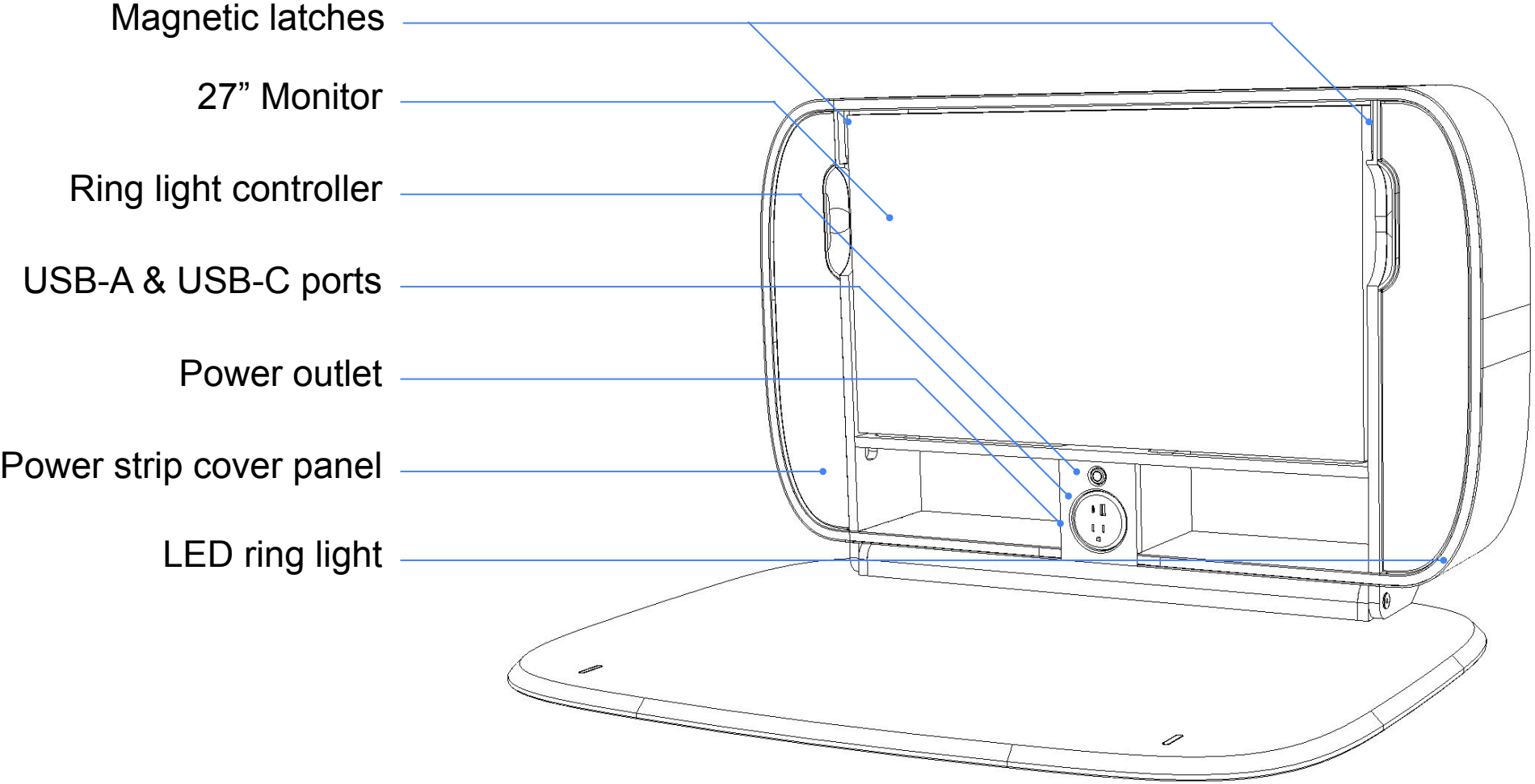

Warnings

Weight limit - Do not exceed 100 lbs of weight on the desk top surface when unfolded. Do not allow children to play on or around desk. Do not exceed 200 lbs total weight of Clamshell Desk and accessories.

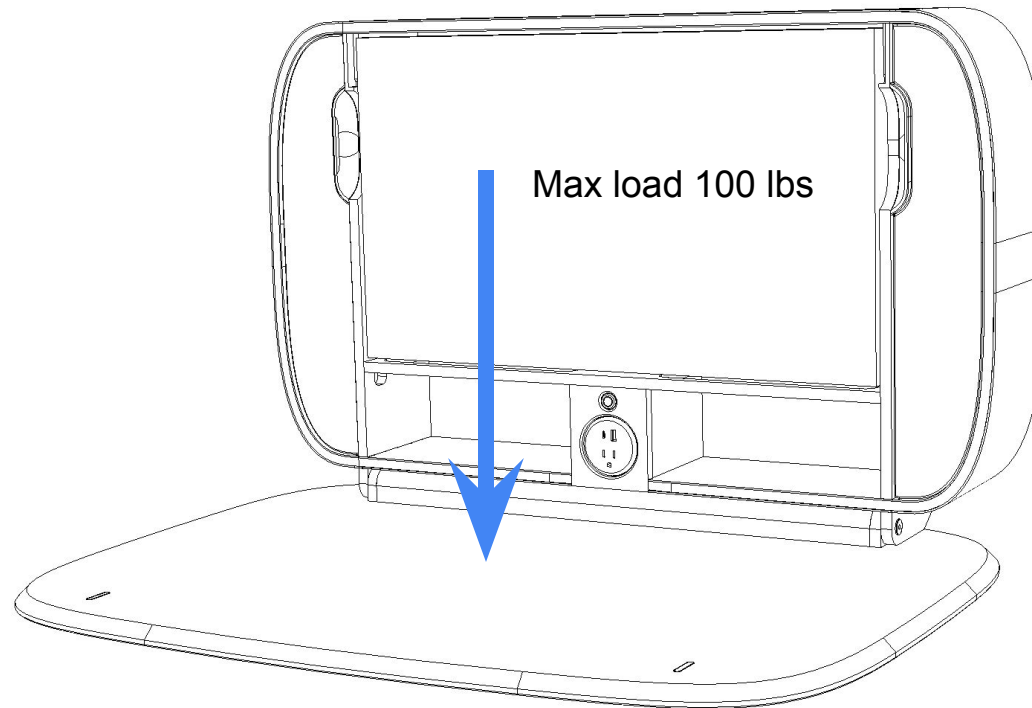

Warnings

Electrical load - Do not exceed 1200W total electrical load on Clamshell Desk power system.

Installation

Required tools:







1. Electric drill
2. 5/32" and 1/4" drill bit
3. PH2 Phillips driver bit
4. 7/16" Wrench
5. Spirit level
6. Tape measure
7. Pencil

Recommended tools:

1. Electronic stud finder

Installation

Included hardware

| Part | Count | Reference image (not to scale) |
|---------------------------|-------|---|
| ¼" x 2.5" Lag bolt | 2 |  |
| 4.5x50mm pan head screw | 2 |  |
| Drywall anchor | 2 |  |
| ¼" Washer | 2 |  |
| Aluminum mounting bracket | 1 |  |
| C13 Power cord | 1 |  |

Installation

Step 1 - Determine desk height

Determine desired height of desk top surface. Your desk height should allow you to keep your arms, wrists and elbows in a neutral position while you work.

Sit or stand as you would at your desk, and hold your arms out in front of your body so that your elbow forms a 90 degree angle. Measure from the floor to the underside of your forearm. This is your **ideal desk height**.

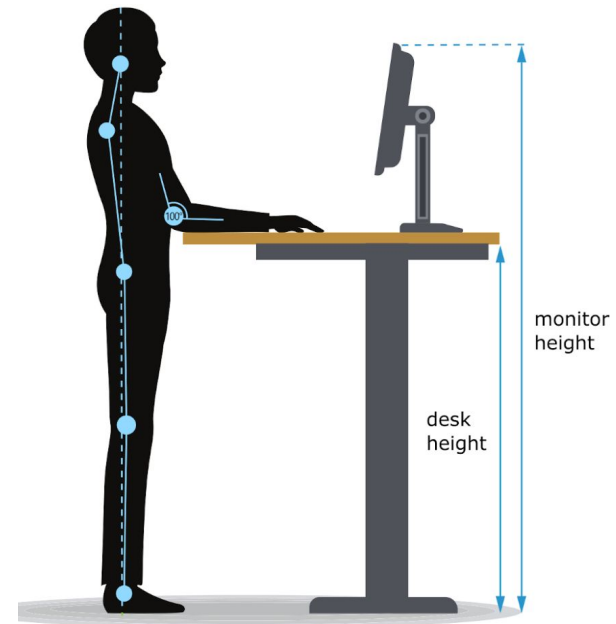
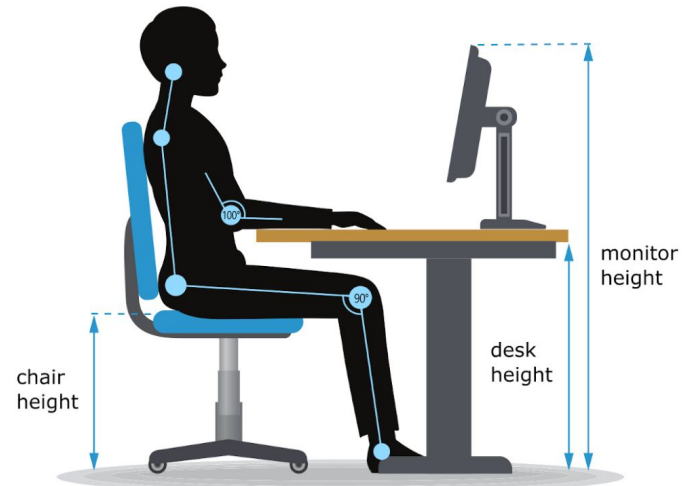

Installation

Step 2 - Mark location of studs on wall

Using electronic stud finder or alternative method, locate and mark the studs in the wall behind where you intend to hang your desk. Locate the stud furthest to the left in the region behind where you intend to hang your desk, and make a mark the distance of ideal desk height (determined in Step 1) + 18.75" (476mm) from the floor. This is the location of your first pilot hole for the mounting bracket.

Pilot hole height = ideal desk height + 18.75"



Installation

Step 3 - Hang mounting bracket on wall

Using your 5/32" drill bit, make a hole in the location determined in Step 2, approximately 2.5" deep. Then, using one of the provided 1/4" lag screws, loosely fasten the mounting bracket to the wall, using the pre-drilled 1/4" hole furthest to the left on the aluminum mounting bracket. **Ensure the bracket is installed with the holes along the bottom edge, and the opening is facing UP.** Using your spirit level, hold the mounting bracket level against the wall, and mark one additional hole location that will allow you to fasten the bracket to the studs in the wall. Drill one additional pilot hole in this location, and loosely fasten with the remaining 1/4" lag screw. **In total your mounting bracket must be attached to two separate studs.** Tighten the lag screws all the way.



Installation

Step 4 - Lift desk into position on wall

With the help of a friend, lift the desk onto the wall bracket. Use one hand to make sure that the desktop stays closed in a vertical orientation. Once on the wall, and with the desk still in the closed position, firmly press down on the top surface of the desk frame, to ensure that the desk is seated on the mounting bracket. Use your spirit level to confirm the desk is level and seated correctly. Gently pull the top edge of the desktop away from the wall to open the desk.



Installation

Step 5 (optional) - Install hard wired outlet

Trace outline of wall plug opening in area behind corkboard onto wall. Remove desk from wall and **hire a licensed electrician** to install a power outlet within this area. The port on the underside of the desk can be bypassed by plugging the power strip behind the corkboard directly into the power outlet on the wall.

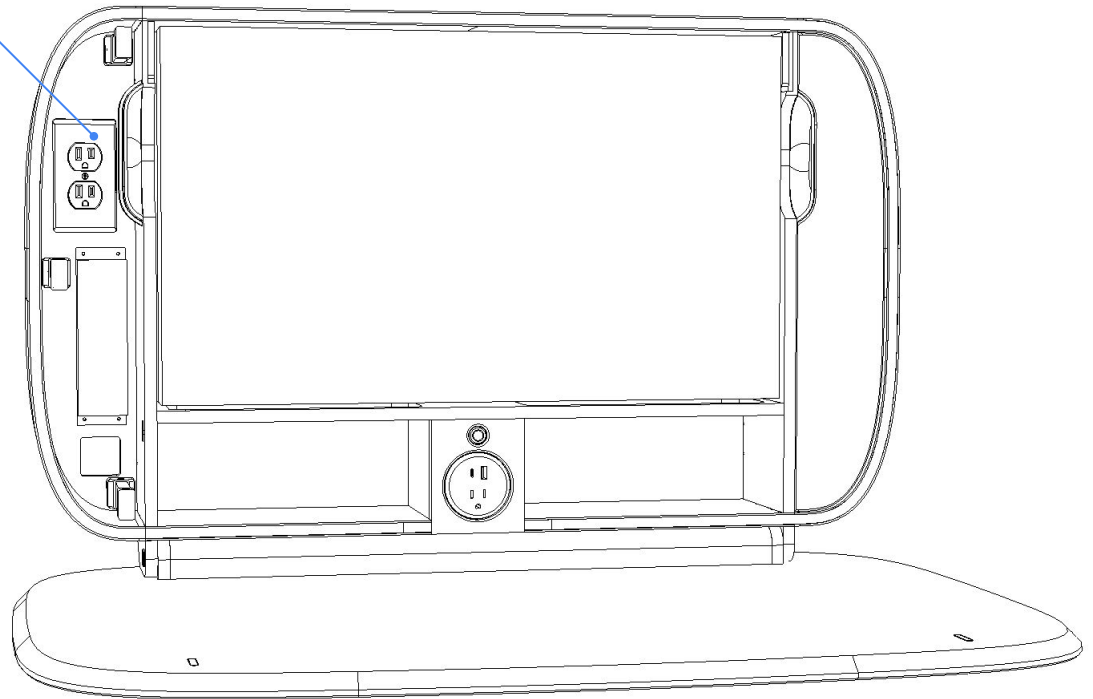

Installation

Step 6 - Mark location for safety screws

Using a pencil, trace the placement of the two safety screw slots, shown in red, onto the wall behind the desk. With the help of a friend, lift the desk off of the wall and install the two drywall anchors roughly in the center of the traced slots by drilling a $\frac{1}{4}$ " hole and pressing the anchors into the hole until they are flush with the drywall.

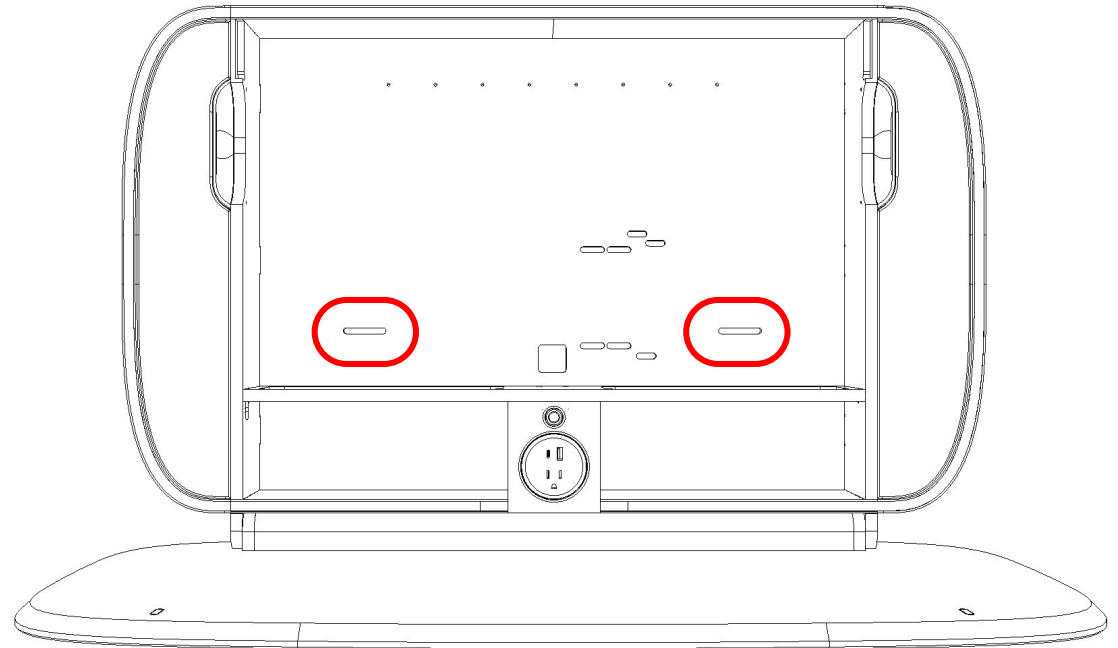

Installation

Step 7 - Install monitor arm

Ask a friend to support the desk frame with the desk on the floor in the open position. Install monitor arm in accordance with the manufacturer's guidelines. The slots used for installation depend on the monitor arm purchased. The stock monitor arm (Mount Pro) attaches to the **RED** slots. The Ergotron LX upgrade monitor arm attaches to the **BLUE** slots.

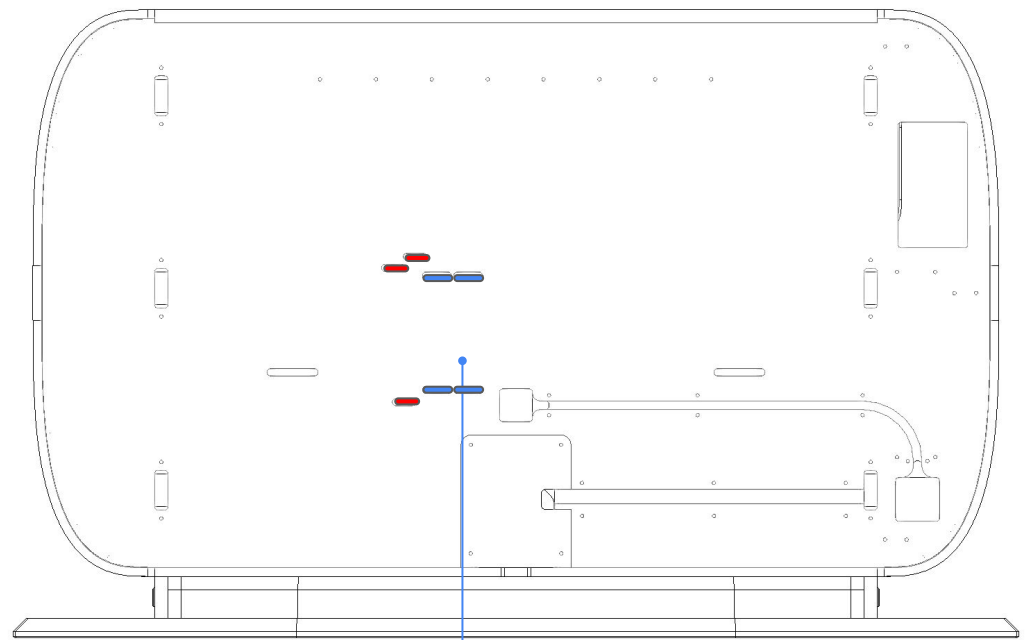

Monitor arm mounting slots
(slots used depend on monitor
arm selected)

Installation

Step 8 - Install monitor

Ask a friend to support the desk frame with the desk on the floor in the open position. Attach monitor to monitor arm in accordance to the included monitor arm instructions booklet. Push monitor into cavity in desk frame and check horizontal alignment. If the monitor arm is not centered or collides with the frame, its position can be adjusted by loosening the attachment bolts and sliding the baseplate side-to-side within the frame. Once the desired placement has been established, tighten down the mounting bolts.

Route the power cable for the monitor along the track in the monitor arm, and through the hole immediately next to the baseplate. On the backside of the desk frame, use a phillips driver to remove the screws holding down the clips for the monitor arm power cable. Press the power cable into the cable groove (shown in red), and reattach the cable clips to secure the cable. Pass the plug through the opening behind the corkboard area, and connect to the power strip. Pull any slack in the cable through the hole and coil behind the corkboard.

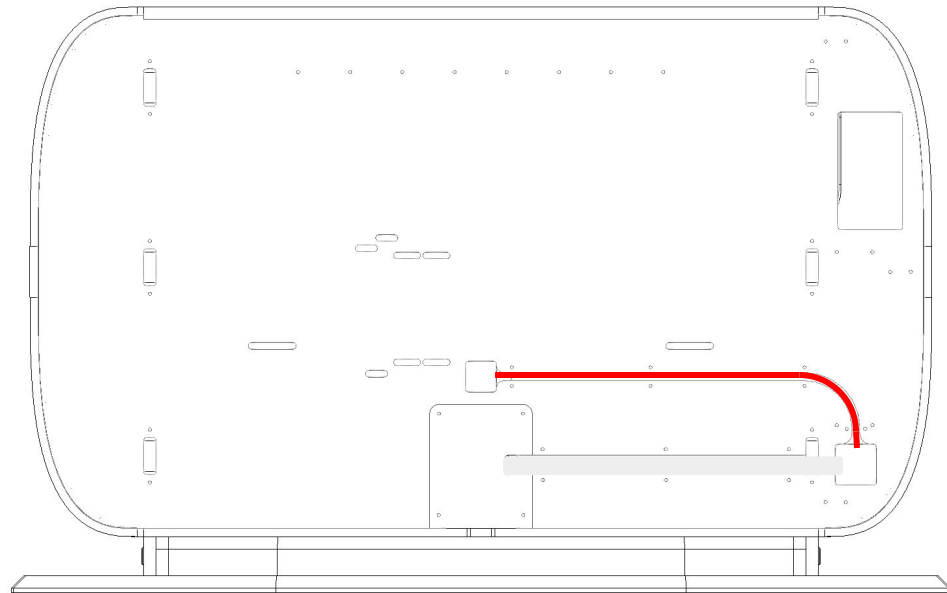

Installation

Step 9 - Lift desk back into position on wall

With the help of a friend, lift the desk back onto the wall bracket. Use one hand to make sure that the desktop stays closed in a vertical orientation. Once on the wall, and with the desk still in the closed position, firmly press down on the top surface of the desk frame, to ensure that the desk is seated on the mounting bracket. Use your spirit level to confirm the desk is level and seated correctly. Gently pull the top edge of the desktop away from the wall to open the desk. Check to make sure the safety screw slots line up with the installed drywall anchors. If not, adjust accordingly.



Installation

Step 10 - Fasten desk to wall with security screws

Using the 4.5 x 50mm pan head screws and 1/4" washer, drive one screw with washer through the safety screw slot and into the drywall anchor. Repeat with the second screw. This is to ensure that the desk cannot accidentally be bumped off of the mounting bracket.

Your desk is now installed and ready to go! Plug it in with the provided C13 power cord.

Drive screws through these slots and into the drywall anchors installed in Step 6

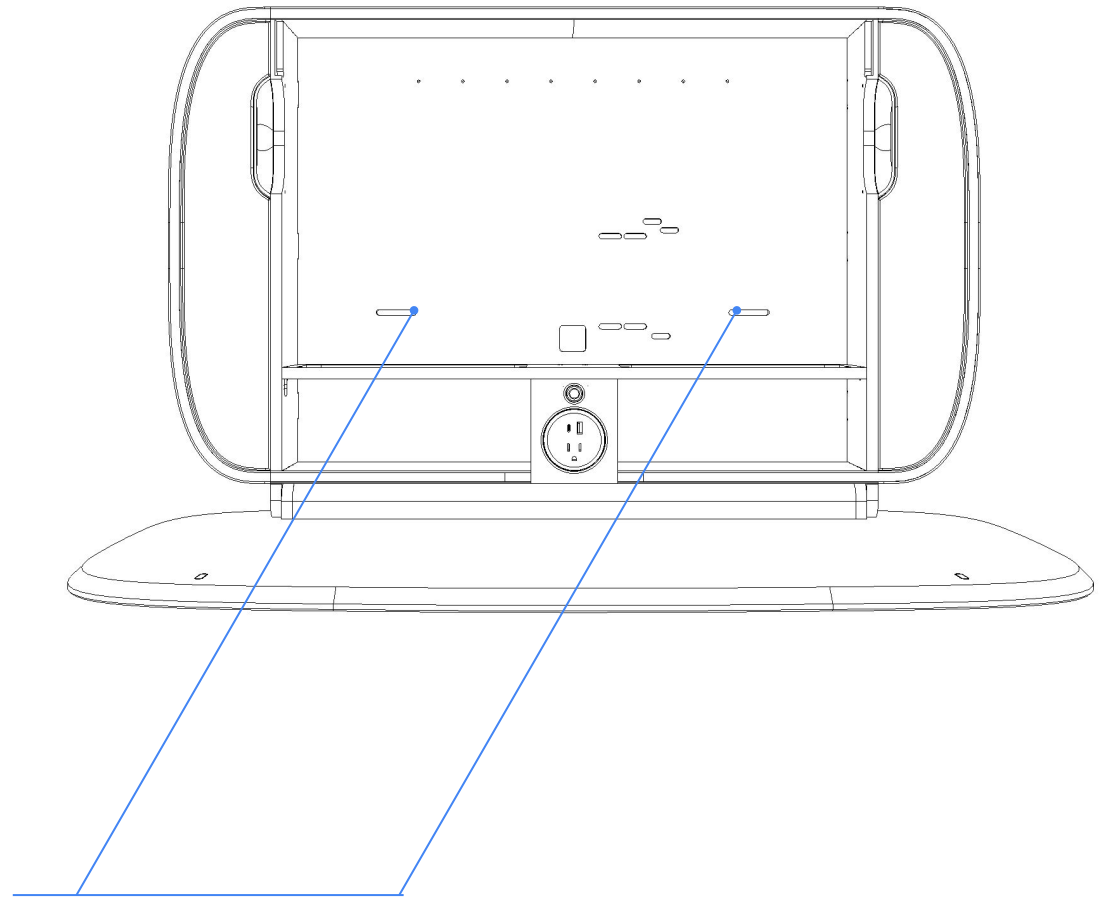

Using your desk

Ring light controller

The ring light is controlled by the black metal pad with the blue light ring directly above the power outlet. Tap once to turn the ring light on and off. While the light is on, touch and hold the black metal pad to adjust brightness.



Using your desk

Opening your desk

Your Clamshell Desk is held closed by strong magnets. Avoid contact with pacemakers or other devices sensitive to magnetism. Use a firm grip and take care when opening the desk. Do not allow the desktop to drop uncontrollably.



Using your desk

Cleaning and care

Disconnect C13 power cord and wipe wood surfaces with a damp cloth.

If wooden hinge squeaks or creaks, it can be lubricated with paraffin or beeswax.

